

Cleaning Technology · Municipal Technology



Citymaster 2200

The powerful sweeping talent

Flexible, fast and safe





State-of-the-art chassis geometry, heavy-duty axles, bigger wheels and all-wheel steering for improved driving characteristics.



Saving time: With its top speed of 62 km/h the Citymaster 2200 can even use motorways and express ways – which reduces travel times from one job site to the next significantly.

Top of the range in the 2-m³-class

The new Citymaster 2200 has been developed to provide maximum economic efficiency, safety and flexibility when it comes to cleaning public areas. Large high-quality components meet the highest standards in modern municipal technology in terms of quality and durability. Equipped with either a two- or three-broom system and with a dirt hopper capacity that is second to none in this class of machines, the vehicle ensures extremely time-efficient sweeping.

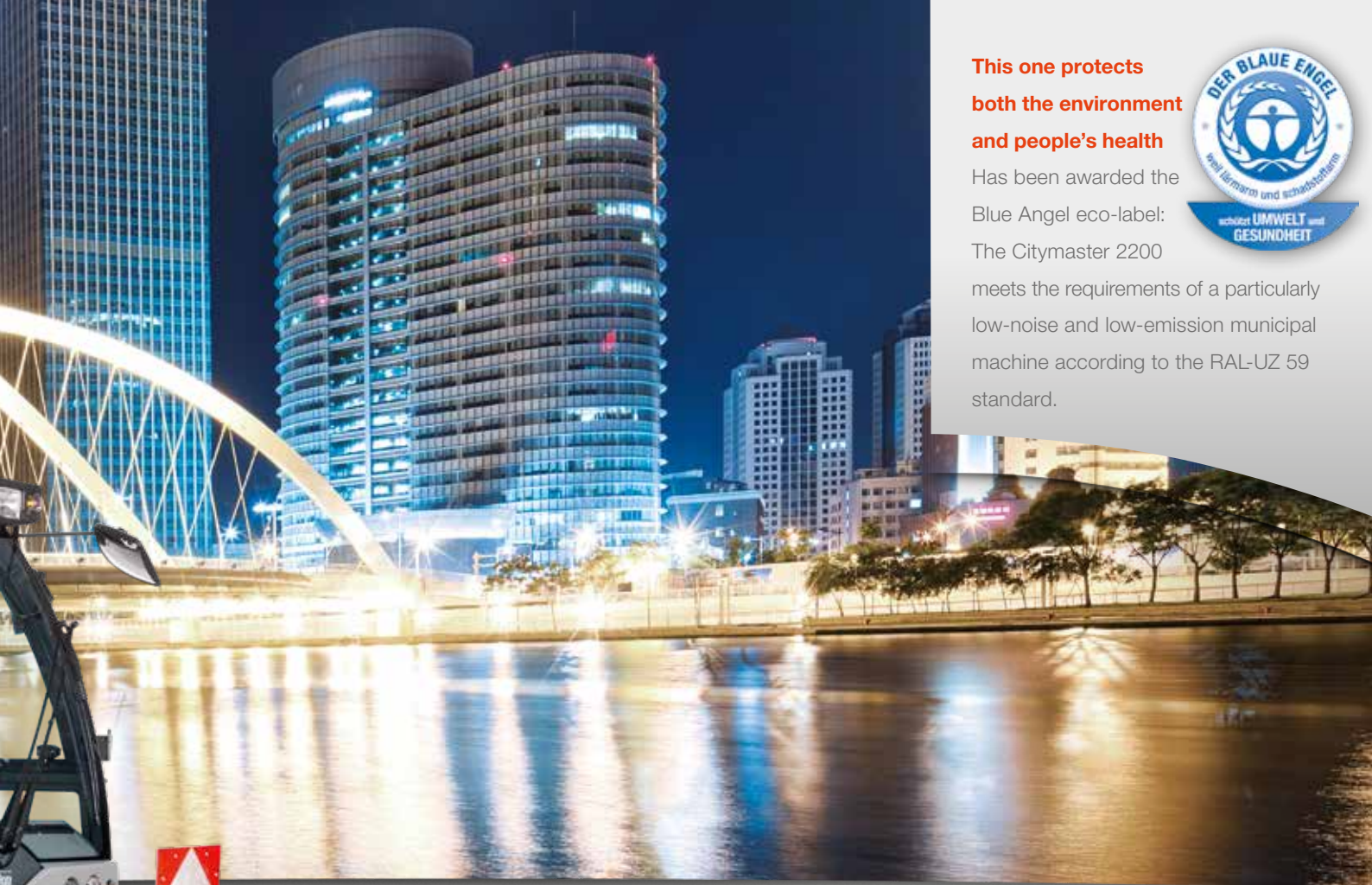

**This one protects
both the environment
and people's health**



Has been awarded the
Blue Angel eco-label:

The Citymaster 2200

meets the requirements of a particularly
low-noise and low-emission municipal
machine according to the RAL-UZ 59
standard.



Three-in-one: Sweeping, wet cleaning, winter service

In addition to its function as a professional sweeper, the Citymaster 2200 is extremely flexible in use. The quick-change system enables easy demounting of the sweeping technology so that the machine can be used for wet cleaning (sluicing, scrubbing) or winter service tasks (snow clearing, gritting). The low-emissions engine with particle filter combined with our ultra-modern, low-noise and low-dust-emissions sweeping technology allows for employment not only in the city but also in quiet residential areas – even early in the morning or late at night.



You can count on us: Hako's compact sweepers and implement carriers are developed and manufactured in Germany.





Go for comfort

The cockpit of the Citymaster 2200 provides optimal working conditions for the driver. Individually adjustable seating position, multiple adjustable steering wheel, large windows for an excellent view with additional camera assistance and equipped with a heating system/air conditioning or heated windscreen/wing mirrors (option): The Citymaster 2200 is perfectly prepared for all-season use.



Easy to operate: The sweeping functions are controlled via joystick and multifunction switch. One-hand operation of all functions.



Back-friendly working:

The Citymaster 2200 scores particularly high points in terms of preventive healthcare at the workplace: from easy entering and exiting the cabin to the back-friendly seat and the comfortable chassis reducing shocks and vibrations during operation. Confirmed by the AGR quality seal awarded to the sweeper.



Ease of use: The sweeper is put into function automatically at the push of a button. For starting work fast and easily!

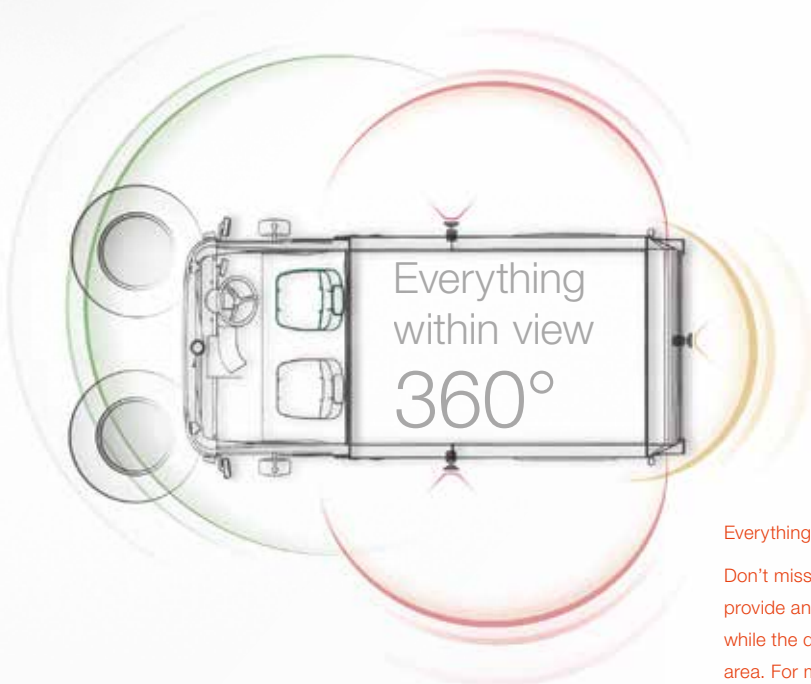

Everything within view on 360°

Don't miss a thing: Optional camera systems provide an additional 270°-angle of vision while the driver can keep his eyes on the work area. For more safety on the road and to reduce the risk of collision damage.

Optimally prepared for long-term use: High-quality commercial-vehicle dip coating and additional wax conservation sustainably protect the entire vehicle against corrosion. Particularly stressed components are made of either stainless steel or plastic or are galvanised.



Flexible technology, exact performance!

Both the 2- and 3-broom systems provide flexibility at the highest level: The sweeping brooms can easily reach even difficult-to-access areas. Additional control functions and power-enhanced drives are optionally available to upgrade the sweeping function and allow both the efficient removal and direct intake of weeds. A range of brooms is available to carry out many different sweeping tasks.

Debris is swept up by the brooms, transported to the suction nozzle and sucked directly and safely into the dirt hopper. The suction nozzle is roller-guided to move both forwards and backwards. The brooms are well protected against collision damage. The circulating water system provides efficient dust control.



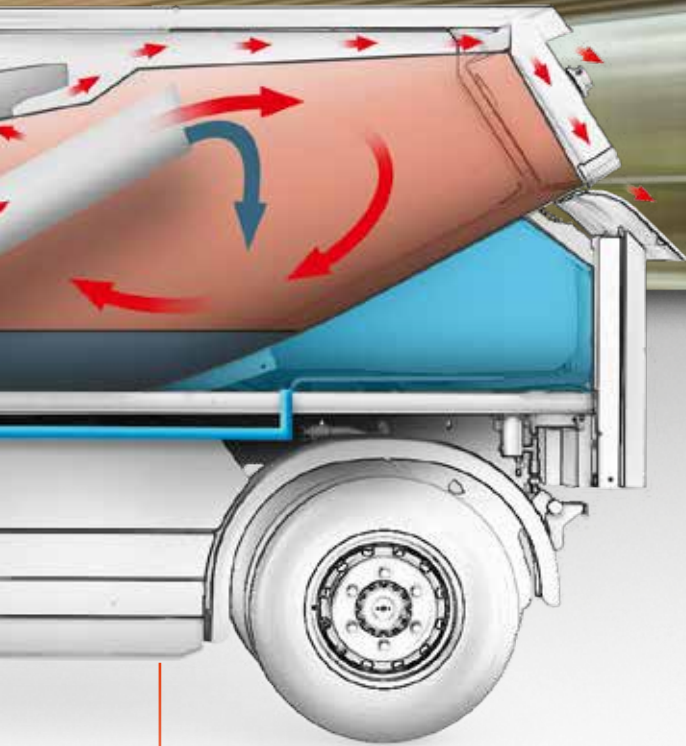

For a maximum sweeping performance: The working width of up to 2.60 m and a height offset of up to 250 mm allow carrying out even complex tasks such as cleaning traffic islands.



From debris intake to disposal

The Citymaster 2200 is equipped with the largest dirt hopper in its class and the high payload makes using the vehicle particularly time-efficient. The stainless-steel dirt hopper with smooth inner surfaces provides both easy emptying and cleaning of the hopper.

99 dB(A)

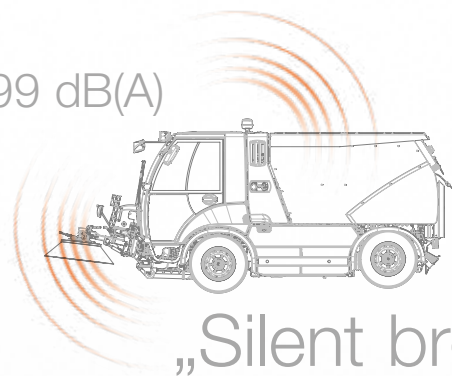

„Silent broom“

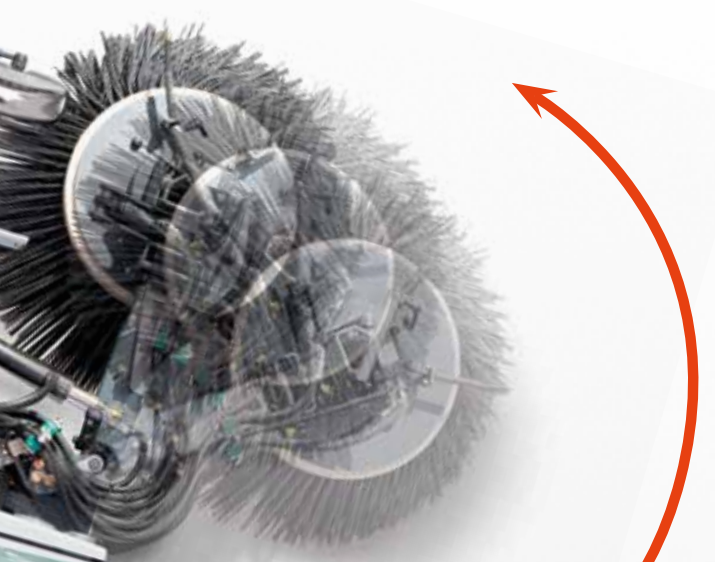

The star in terms of particulate emission

Approved by highest possible ranking in EUnited PM 10 Test.



Clean cities – at any time of year

The Citymaster 2200 is extremely flexible: In the summer, when sweeping is not enough, the machine can be used for wet cleaning tasks. And in the cold season, the compact sweeper can easily be converted into a winter service vehicle. ABS and an optionally available differential lock provide safe working in icy and snowy conditions.

The quick-change system facilitates equipping the vehicle for winter service: Ease-of-installation provides fast re-tooling and a high level of flexibility for all-season use.



Optional equipment:

Sluicing systems with different outputs as well as a scrub deck attachment for wet cleaning tasks, a range of snow blades and a front sweeper for efficient snow clearing as well as professional silo gritting units and a brine spraying system to fight ice and snow enable flexible all-season use that helps minimising your fleet costs significantly!



Citymaster 2200

Wet cleaning for brilliant results

For cleaning large paved areas and natural stone surfaces: The scrub deck of the Citymaster 2200. For interchangeable use with the sweeping unit and in combination with additional equipment for the suction nozzle, the scrub deck enables removing even stubborn dirt from smooth surfaces. Direct waste-water intake provides a maximum of cleanliness.

Providing dust control as well as cooling and cleaning of roads and paths: The sluicing systems of the Citymaster 2200. For interchangeable use with the sweeping technology. The system is equipped with a large water tank and a range of sluicing bars with different outputs is available. The waste water can be released into the sewage system.



SAFETY FIRST

Safety standards of the highest level

Safety starts with the vehicle concept. When developing our products, we follow the same high standards that apply in the truck construction industry, which includes a safety concept for the driver's cabin as well as disc brakes and ABS integrated into the hydrostatic drive. Daytime running light as a standard, large reflectors, bright LED flashing beacon ... we do everything for the driver's safety. In addition, all our vehicles are thoroughly tested. We attach a great deal of importance to the quality of our components in order to ensure both safety and durability.

The driver's safety is very important to us. That is why we carry out safety tests to the highest standards in order to ensure a maximum of safety in the cabin.



Nr. 201537317





For more safety on the road

Elaborately spring-mounted heavy-duty commercial vehicle axles 'made in Germany' provide the high payload of the Citymaster 2200 and ensure safe driving and operation. The heavy-duty non-deforming frame, providing optimal road-holding characteristics in all operating situations, is another aspect of the safety concept.

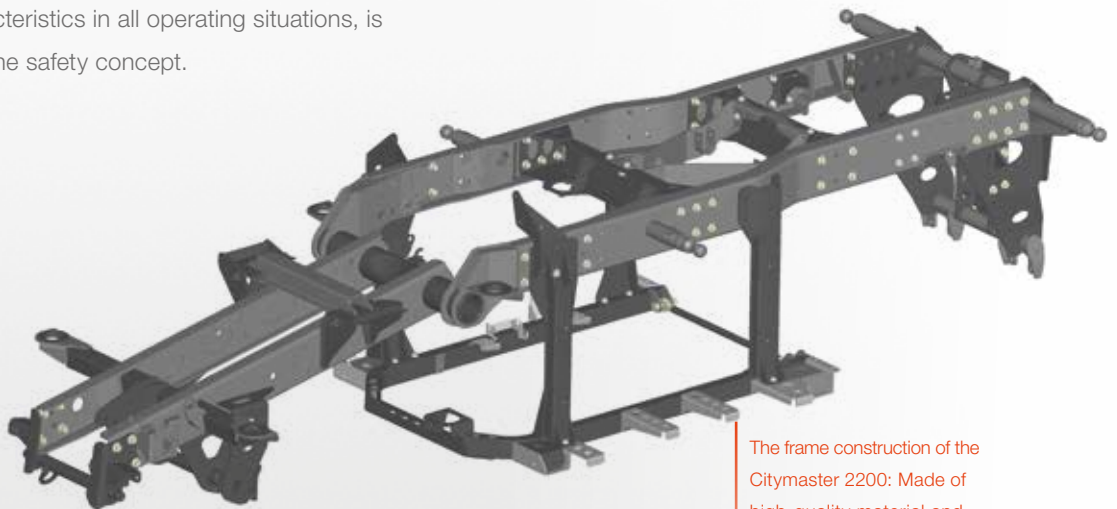

The frame construction of the Citymaster 2200: Made of high-quality material and manufactured in Germany, robust and non-deforming – a safe basis.





We are there for you 24/7: Thanks to a close-knit sales and service network

650 service technicians are available Europe-wide to provide servicing and maintenance of Hako compact sweepers. The close-knit service network offers one major advantage: You can be sure that the workshop of one of our service partners is in your vicinity so that necessary maintenance work can be carried out efficiently and at short notice.



Our extensive network of authorised service partners: Always close to the customer, throughout Germany.





The experts for your vehicle

Competent workshops with experienced service technicians carry out regular maintenance work on the vehicles.

Customers benefit from the vehicle's maintenance-friendly design that helps to reduce the time spent at the workshop to a minimum.



Technical data

	Citymaster 2200 2B	Citymaster 2200 3 B
Engine and drive		
Engine	VM R754 EU6 D3 four-cylinder turbo diesel according to directive 595/2009/EC EURO VI, intercooler, diesel-Oxicat, particle filter, SCR cat, tank capacity 65 l	
Displacement/output	2,970 cm ³ / 80 kW (109 HP) at 2,600 rpm	
Max. torque	420 Nm at 1,100 rpm	
Working and driving characteristics		
Driving	Fully hydraulic drive, rear-wheel drive, driver-selected all-wheel steering, optional differential lock 3 different operating modes: Transport mode with automatic speed & load control; Work mode with constant speed, changing from drive mode to work mode at constant speed; Transport mode up to 62 km/h, standard steering; Changing from drive to work mode up to 25 km/h, all-wheel steering; Work mode up to 15 km/h, all-wheel steering; Reverse mode up to 10 (25) km/h	
Working	Load-sensing high pressure hydraulics with variable power distribution; 3 different operating modes: ECO/Standard/MAX switchable at the push of a button; Fan with engine-independent speed control; Additional functions with optional multi-purpose package	
Attachment points	Quick-change triangle cat 0 at the front, quick-change ball-mounting system at the rear	
Frame, chassis, brakes	Commercial-vehicle lead frame with 2 steering axles, coil springs with shock absorbers, stabiliser at the rear axle, 4 attachment points for standard lifting platform, dual-circuit braking system with 4 disc brakes and brake booster, Anti-Lock-Brakes (ALB), variable hydrostatic braking power, independent mechanical parking brake acting on the rear axle	
Wheels and tyres	Standard tyres 225/75 R16C Wide tyres 285/65 R16C	
Cabin	2-seater comfort cabin, occupant-protection tested according to ECE R29 adjustable steering column, comfort seats, 3-point seat belt, comfortable one-hand operation of all sweeping functions, one-button operation to start the sweeping functions, automatic memory-storing of all operating parameters	
Sweeping system	2-broom 900 mm, working width up to 2,500 mm, suction nozzle 800 mm on rollers	Pre-sweep broom 900 mm, 2 basic brooms 750 mm, working width up to 2,000 mm, suction nozzle 800 mm on rollers
Dirt hopper	V2A stainless steel dirt hopper 2.2 m ³ , gross capacity 1,895 l, usable hopper capacity 1,710 l	
Dimensions and load values		
Length/width/height*	4,950 mm / 1,320 mm / 2,054 mm	4,975 mm / 1,320 mm / 2,054 mm
Wheelbase/track width	2,190 mm / 1,054 mm	
GVW	6.000 kg	
Permissible axle loads	3,200 kg / 3,200 kg	
Empty weight**	3,540 kg	3,650 kg
Payload***	Up to 2,460 kg	Up to 2,350 kg

Form, colour and design are subject to change in favour of further technical development. Pictures may show optional equipment. Details according to EN 15429 1-4 where applicable.

* Width: without wing mirrors, height: with standard tyres

** Empty weight: standard machine without optional equipment

*** Payload: Optional equipment may reduce the payload

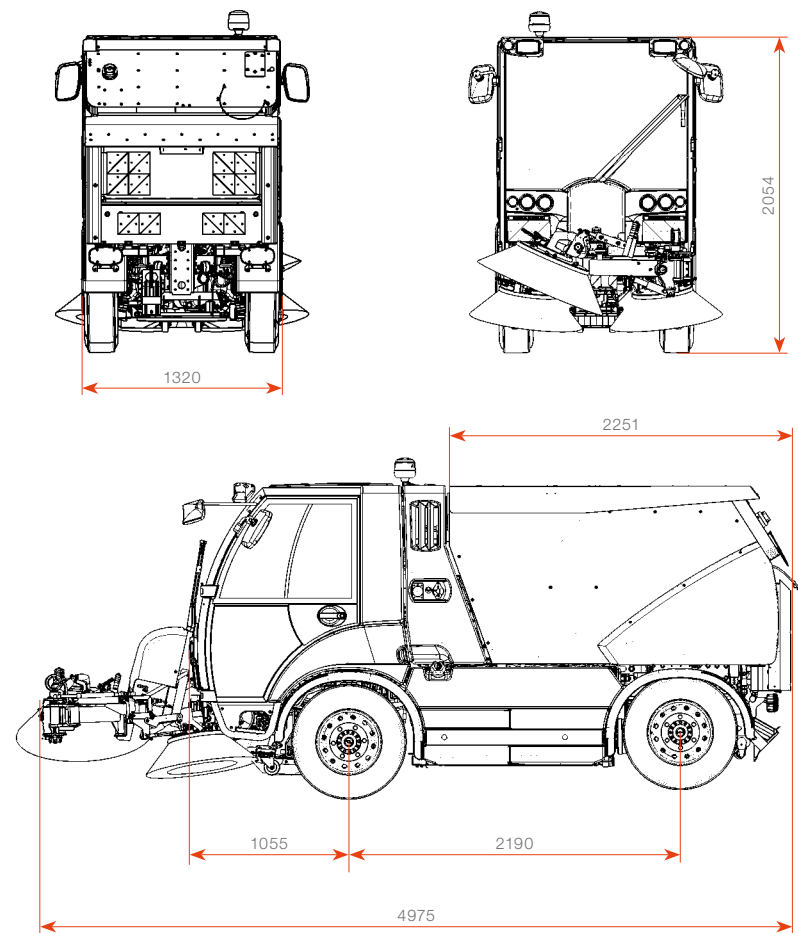
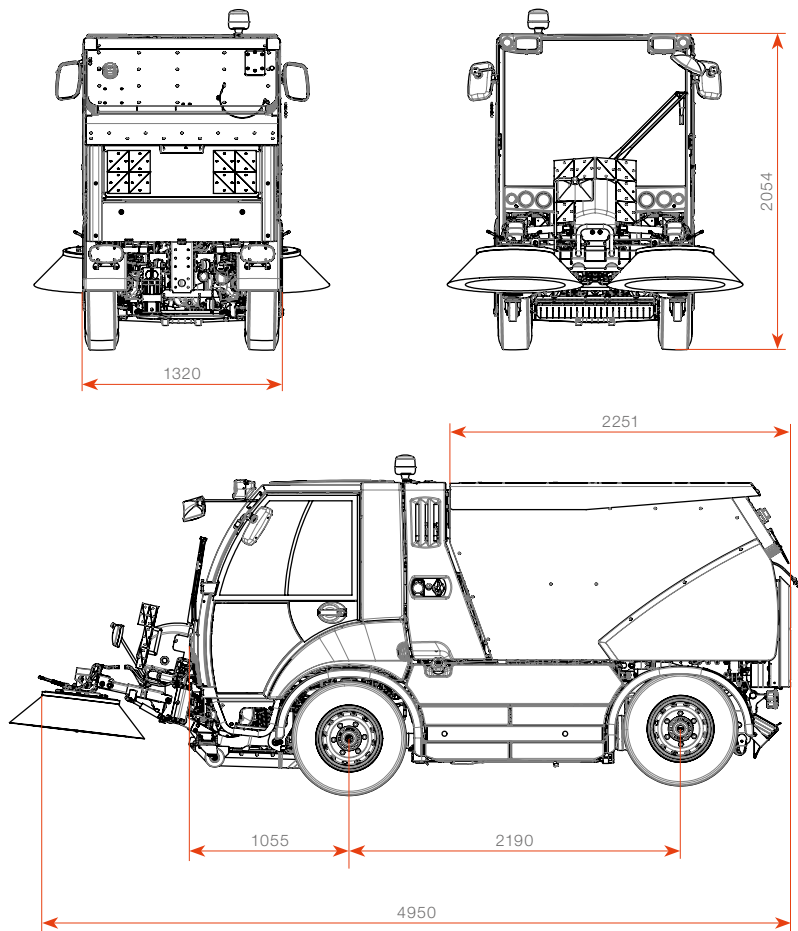

For even more efficient working: Optional equipment for your Citymaster 2200

For example useful accessories such as a high-pressure cleaner or a hand-held suction hose and many more practical details. Please ask your Hako retailer for further information!



Hako: environmental-friendly right from the start

It is our legacy to leave behind a clean planet. That is why resources-, environmental- and climate protection characterize each and every process at Hako which has been certified by independent institutions. Learn more about our on-going commitment at www.hako.com

Everywhere and close by

Our efficient close-knit sales & service network guarantees close proximity and rapid help.

Buying, leasing, renting

We offer you a number of individual and attractive financing & procurement options.

We are available 24/7

Hako's spare part express- and on-call service guarantees best possible availability.

Cleanliness combined with safety

Our machines meet the highest standards. Reliable quality "Made by Hako".



AGR quality seal (Aktion Gesunder Rücken (AGR) e. V.): Tested and recommended by the Forum: Gesunder Rücken - besser leben e.V. (German association promoting healthy backs) and the Bundesverband deutscher Rückenschulen (BdR) e.V. (Federal Association of Back Training Facilities), for further information contact: AGR e.V., Stader Straße 6, 27432 Bremer-vörde · Phone: +49 (0) 4761-92 63 580 www.agr-ev.de

Hako GmbH
 Head Office
 Hamburger Str. 209-239
 23840 Bad Oldesloe
 Tel. +49 (0) 4531- 806 0
info@hako.com
www.hako.com